



FASTECH 24 KI - 24 KIS

EN - INSTALLER AND USER MANUAL

FR - MANUEL D'INSTALLATION ET D'UTILISATION

RIELLO

EN **FASTECH** boiler complies with basic requirements of the following Directives:

- Gas directive 2009/142/EC;
- Efficiency directive: Article 7(2) and Annex III of directive 92/42/EEC;
- Electromagnetic compatibility directive 2014/30/EU;
- Low-voltage directive 2014/35/EU.

Installer's - user's manual.....	3-13
Boiler operating elements.....	34
Hydraulic circuit	35
Electric diagrams	37
Circulator residual head.....	39

The following symbols are used in this manual:



CAUTION = operations requiring special care and adequate preparation



NOT ALLOWED = operations that **MUST NOT** be performed

FR La chaudière **FASTECH** respecte les conditions de base requises par les Règlements suivants:

- Directive sur le gaz 2009/142/CEE;
- Directive sur le rendement: Article 7(2) et Annexe III de la directive 92/42/CEE;
- Directive sur la compatibilité électromagnétique 2014/30/EU;
- Directive sur la basse tension 2014/35/EU.

Manuel d'installation-Manuel de l'utilisateur	18-29
Éléments fonctionnels de la chaudière.....	34
Circuit hydraulique.....	35
Schémas électriques	37
Prévalence résiduelle du circulateur.....	39

Dans certaines parties du manuel on utilise les symboles:



ATTENTION = actions demandant une certaine prudence et une préparation adéquate





INTERDICTION = actions **NE DEVANT** absolument **PAS** être exécutées

INSTALLER MANUAL

1 - WARNINGS AND SAFETY INSTRUCTIONS

 After removing the packaging, make sure that the product is integral and complete with all its parts. If it does not correspond with the order made, please contact the Riello Agency that sold the boiler.

 The boiler must be installed by a qualified company in accordance with the regulations in force and in observance of applicable legislation and of the indications provided by Riello in the present instructions booklet.

 The installer explains how the appliance operates to the user, and the basic safety regulations.

 The boiler must be used for the purpose envisaged by the producer, for which it was expressly made. No contractual or extracontractual liability is accepted by Riello for damage caused to people, animals, or objects due to errors in installation, adjustment, or maintenance or by improper use.

 In the event of a water leak, shut-off the water supply and promptly notify the Technical Assistance Service or a professionally qualified technician.

 Check regularly that the hydraulic system operating pressure is between 1 and 1.5 bar. If the pressure is not between these values, fill the system as indicated in the specific chapter. In the event of frequent pressure drops, please seek assistance from the Technical Assistance Service or a professionally qualified technician.

 If the boiler will not be used for a prolonged period of time, you must:

- turn the main switch of the device and the general system switch to "off"
- shut off the heating system gas and water cocks
- empty the heating system and the domestic hot water (DHW) system if there is a risk of freezing.

 Boiler maintenance must be carried out at least once a year.

 This manual and the user manual are an integral part of the device. They must be carefully preserved and must always accompany the boiler, even if it is sold to another owner or user, or transferred to another facility. If lost or damaged, please request another copy from the Technical Assistance Service for your area.

 The boilers are designed to protect both the user and installer from any accidents. After any intervention on the product, take care to restore the electrical connections. Take special care with stripped sections of wire, which must never protrude from the terminal board.

 Dispose of packaging materials in the relevant containers at authorised waste collection centres.

 Waste must be disposed of without any risk to personal health and safety and without adopting procedures or methods that may be harmful to the environment.

 At the end of its lifetime, the product must not be disposed of as solid urban waste but must be delivered to a specialised waste disposal centre for recycling.

 The air vents are essential for correct combustion and for safety (only KI model).

Please remember that in using products which involve gas, electricity and water, you must adhere to some basic safety requirements:

 Children and unassisted disabled persons must not use the boiler.

 Do not operate devices or electrical appliances such as switches or domestic appliances, etc. if you can smell gas or unburned gas. Should this occur:

- open the doors and windows to ventilate the room
- close the gas shut-off device
- call the Technical Assistance Service or a professionally qualified technician immediately.

 Do not touch the boiler when barefoot or with any wet parts of the body.

 Do not clean the boiler without having disconnected it from the mains power supply by setting the power switch to "off".

 Do not modify the safety or adjustment devices without prior authorisation or instructions from the boiler manufacturer.

 Do not pull, disconnect or twist the electrical cables coming from the boiler, even if it is disconnected from the mains electricity supply.

 Do not seal off or reduce the size of the air vents (if present) in the room where the boiler is installed.

 Do not leave containers of flammable substances in the room where the boiler is installed.

 Dispose of packaging responsibly and keep all packaging material out of the reach of children, as this is a potential source of danger.

2 - DESCRIPTION

FASTECH is a wall-mounted gas boiler for central heating and domestic hot water, with a bithermal exchanger in braze-welded copper.

The boiler is controlled electronically with automatic ignition, ionisation flame control, modulating in heating and DHW mode.

FASTECH KI: it is fitted with an open combustion chamber and classed in category B11BS.

FASTECH KIS: has a sealed combustion chamber and based on the gas discharge accessory used, is classified in B22P, B52P; C12, C12x; C22; C32, C32x; C42, C42x; C52, C52x; C82, C82x; C92, C92x categories.

To guarantee the correct water flow in the exchanger, the boiler is fitted with an automatic bypass device.

It is also complete with the safety, expansion and distribution accessories.

FASTECH boiler is fitted with:

- microprocessor control and management with self-diagnostics
- pump anti-block function and 3-way valve
- first level anti-freeze (suitable for indoor installations)
- provision for room thermostat or timer or zone valve
- digital display indicating operating temperature and fault codes.

2.1 Safety devices

FASTECH boiler is equipped with the following safety devices:

- **Safety valve and water pressure switch**, which intervene in the event of insufficient or excessive water pressure (min. 0.7 bar - max. 3 bar).
- **Water temperature limit thermostat**, which intervenes setting the boiler to safety stop status if the temperature exceeds the values envisaged by current standards.
- **FASTECH KI: Fumes thermostat**, which intervenes setting the boiler to safety stop status if combustion products return in the hood. It is located on the right tile of the draught diverter mechanism.
- **FASTECH KIS: Differential air pressure switch**, which intervenes by placing the boiler in a state of security stop in case of faults in the fume exhaust circuit.

 If a safety device is tripped, there is a boiler fault. Please contact the Technical Assistance Service immediately.

The **fumes thermostat** and the **differential air pressure switch** are tripped not only by a defect in the combustion product evacuation circuit, but also by random atmospheric conditions.

Therefore, after a short wait, the boiler can be restarted (see the chapter "First start-up").

FASTECH KI: If the fumes thermostat trips repeatedly, this means combustion products are evacuated towards the boiler installation area. This means combustion may be incomplete and there is a risk of carbon monoxide forming. This is a serious hazard. In this case, please contact the Technical Assistance Service immediately.

The boiler must not be operated, even temporarily, if the safety devices are not functioning or have been tampered with.

The safety devices must be replaced by the Technical Assistance Service, using original manufacturer components only. Please see the spare parts catalogue supplied with the boiler.

After repairs, always perform an ignition test.

3 - INSTALLATION

FASTECH KI: In existing buildings, this natural draught boiler must only be connected to a flue system shared by several homes to evacuate the combustion residue outside the room where the boiler is installed. For combustion, the boiler takes in air directly from the room and is equipped with a draught diverter. Due to reduced efficiency, any other use of this boiler must be avoided at all times, as this would lead to increased energy consumption and higher operation costs.

3.1 Product delivery

The **FASTECH** boiler is supplied in a single box protected by carton packaging.

The boiler is supplied with the following material:

- installer and user manual
- labels with bar code
- screws and plugs
- flange \varnothing 42 (only KIS models).

The instruction manuals are an integral part of the boiler. Please read the manuals and store them in a safe place.

3.2 Dimensions and weight (fig. 1)

	FASTECH 24 KI	FASTECH 24 KIS	
L	400	405	mm
P	328	240	mm
H	740	715	mm
Net weight	30	28	kg

3.3 Handling

After removing all packaging, the boiler is handled manually using the support frame (fig. 2).

3.4 Installation room

FASTECH KI

The boiler must be installed in rooms fitted with suitably sized ventilation outlets compliant with current technical standards.

FASTECH KIS

In configuration C, the appliance can be installed in any type of room and there are no limitations due to ventilation conditions or room volume since the boiler has an "airtight" combustion circuit in relation to the installation environment.

In configuration B22P and B52P the appliance cannot be installed in bedrooms, bathrooms, showers or where there are open fireplaces without a proper air flow. The room where the boiler is installed must have proper ventilation.

Take into consideration the space that is required to access the safety and control devices and to perform maintenance.

Check that the appliance's electrical protection rating is suitable for the place of installation.

If the boiler is run on combustible gas of a specific weight greater than that of air, the electrical parts must be positioned at a minimum height of 500 mm from the ground.

FASTECH KI: The boiler cannot be installed outside as it is not designed for operation outdoors.

3.5 Installation in older systems or circuits requiring renovation

When **FASTECH** boilers are installed in older systems or systems requiring renovation, ensure that:

- the flue exhaust is suitable for the temperatures produced by combustion, calculated and built in line with the regulations, and is as straight as possible, airtight, insulated and not blocked or constricted
- the electrical system complies with the specific regulations and is installed by qualified technicians
- the gas conveyance line and any tanks (LPG) comply with specific regulations
- the expansion tank ensures full absorption of the expansion of the fluid in the system
- the flow rate and useful head of the pump are suitable for the system
- the system is washed, free of all dirt and build-up, de-aerated and correctly sealed
- there is a treatment system when the supply/top-up water is of a specific type (see the table for possible reference values).

Supply water values	
pH	6-8
Electrical conductivity	less than 200 μ S/cm (25°C)
Chloride ions	less than 50 ppm
Sulphuric acid ions	less than 50 ppm
Total iron	less than 0.3 ppm
Alkalinity M	less than 50 ppm
Total hardness	less than 35°F
Sulphur ions	None
Ammonia ions	None
Silicon ions	less than 20 ppm

The manufacturer declines all liability for possible damage caused by incorrect installation of the flue outlet system.

If the supply water has a total hardness of between 25°F and 50°F, install the domestic water kit (polyphosphate dispenser). If the total hardness is above 50°F, the kit progressively decreases in efficiency and a higher performing appliance or a water softening system should be installed. In case of total hardness below 25°F, a suitably sized filter should be installed if the water supplied from the mains is not perfectly clean/cannot be cleaned.

3.6 Boiler installation

To install the boiler correctly, please remember that:

- the boiler must not be installed above a stove or other cooking equipment
- flammable substances must not be left in the room where the boiler is installed
- walls sensitive to heat (for example those in wood) must be protected with suitable insulation
- minimum clearances must be observed to enable technical interventions and maintenance.

FASTECH KI

Installation must be carried out by qualified personnel, in accordance with the regulations in law. In particular UNI 7129-7131 and CEI 64-8 and 64-9 must be respected.

FASTECH KIS (fig. 3a)

The boiler can be installed indoor and outdoor.

Indoor installation: it may be installed in numerous rooms as long as the combustion product outlet and combustion air suction are brought outside the room itself. In this case, the room does not require any ventilation opening because these are boilers with an "airtight" combustion circuit in relation to the installation environment.

If, instead, the combustion air is picked up from the installation room, the latter must be equipped with ventilation openings compliant with Technical Standards and suitably dimensioned.

Consider the clearances necessary to access safety and adjustment devices and to perform maintenance operations.

Check that the electric protection level of the appliance is adapted to the installation room characteristics.

In case the boilers are supplied with fuel gas of a specific weight greater than that of the air, the electric parts will have to be placed at a level above the ground greater than 500 mm.

Outdoor installation: the boiler can be installed outdoor, in a partially protected place (i.e. a place where the boiler is not exposed to direct contact or infiltration of rain, snow or hail). The boiler is fitted as standard with an automatic anti-freeze system that activates when the water temperature in the primary circuit falls below 6°C. To take advantage of this protection, based on the burner operation, the boiler must be able to switch itself on; any lockout condition (i.e. due to a lack of gas or electrical supply, or the intervention of a safety device) therefore deactivates the protection.

FIXING THE BOILER

The **FASTECH** boiler has been designed and produced to be installed in heating and domestic hot water production systems. The position and dimensions of the hydraulic fittings are stated in the illustrations.

- Position the support plate using a spirit level. Check it is horizontally level and that the boiler support surface is flat. If necessary, add shims to level the surface correctly.
- Mark the fixing points referring to the indication "plug the hole".
- Remove the plate and drill the holes.
- Fit the plugs.
- Use a spirit level to check the plate is level.
- Hook up the boiler to the plugs (fig. 4).

3.7 Hydraulic connections (fig. 5)

Connect the fittings and seals supplied with the system. Connect the boiler to the system by inserting both the domestic water shut-off valve and the heating system shut-off valves. A specific heating system valve kit and heating valve kit with filter are available.

M	heating delivery
AC	hot water outlet
G	gas
R	heating return
AF	cold water inlet

The choice and installation of system components is left to the discretion of the installer, who must operate according to the rules of good technical practice and current legislation.

If the supply water has a total hardness of between 25°C and 50°F, install the domestic water kit. If the total hardness is above 50°F, the kit progressively decreases in efficiency and a higher performing appliance or a water softening system should be installed. In case of total hardness below 25°F, a suitably sized filter should be installed if the water supplied from the mains is not perfectly clean/cannot be cleaned.

The boiler safety valve outlet must be connected to an adequate collection and drainage system. The boiler manufacturer declines all liability for any flooding caused by the safety valve.

A carry case kit is available so that connections can be made quickly, without wasting time on each system.

3.8 Electrical connections (fig. 6 - 7 - 8)

The **FASTECH** boiler is factory-wired and the electrical power cable is already connected. The room thermostat/s (TA) must simply be connected to the relative terminals.

- Turn the main system switch to "OFF".
- Unscrew the case fixing screws (A).
- Move the bottom of the case forward and then upwards to detach it from the frame.
- Unscrew the panel screws (B).
- Turn the control panel forwards.
- Open the cover (C) to access the control board.

The boiler operates with alternating current at 230 V/50 Hz and is compliant with standard EN 60335-1.

Low-voltage safety room thermostat (voltage-free contact).

When using a phase-phase power supply, use a tester to determine which of the two wires has the greater potential compared to the earth and connect it to the L terminal. Connect the remaining wire to the N terminal.

The boiler can also operate with a phase-neutral or phase-phase power supply. For floating power supplies, i.e. those which have no earth connection, use an insulation transformer with a secondary circuit connected to the earth.

The earth wire must be approximately 2 cm longer than the other wires.

YOU MUST:

- use a general trip-switch to disconnect the line in compliance with Italian CEI-EN 60335-1 standards (contact opening at least 3.5 mm, category III)
- use cables with a cross-section of $\geq 1.5 \text{ mm}^2$ and respect the L (phase) - N (neutral) connection
- ensure that the amperage on the switch is adequate for the boiler's electrical power rating. Please refer to the technical data to check the electrical rating of the model installed
- connect the appliance to an efficient earthing system
- ensure that the power socket can be accessed after installation.

Do not use gas or water pipes to earth this appliance.

The manufacturer declines any liability for damage caused by failure to comply with the wiring diagrams.

The installer is responsible for ensuring that the appliance has an efficient earthing system. The manufacturer declines all liability for any damage caused by a faulty earthing circuit or the lack of an efficient earthing circuit.

3.9 Gas connections

The **FASTECH** boilers must be connected to the main gas supply in compliance with current installation standards.

Before connecting the appliance, ensure that:

- the type of gas is compatible with the boiler model being installed.
- all pipelines are thoroughly cleaned.

The gas supply system must be suited to the flow rate of the boiler and must be fitted with all safety and control devices as envisaged by current standards. A suitable sized filter should also be used.

At the end of installation, check all connections are properly sealed.

3.10 Flue gas outlet and combustion air suction

FASTECH KI (fig. 9)

The discharge pipeline and connection to the flue must comply with current local and national standards and legislation.

Use rigid ducts. Joints between parts must be airtight. All components must be resistant to high temperatures, condensate and mechanical stress.

These boilers are equipped with a fumes thermostat positioned on the right side of the hood. If combustion products are returned, this device immediately shuts down operation of the boiler.

The combustion air vents must comply with current technical standards.

Discharge ducts without insulation are a potential source of danger.

Do not seal off or reduce the size of the air vents in the room where the boiler is installed.

FASTECH KIS (fig. 10a-b-c-d-e-f-g-h)

The boilers must have appropriate ducts for fumes outlet and air intake, according to the type of installation. Ducts are an integrant part of the boiler but are supplied in separate kits, for improved installation flexibility.

The maximum lengths of the ducts refer to flue systems available in the catalogue.

"FORCED OPEN" INSTALLATION (TYPE B22P-B52P)

Fumes outlet duct $\varnothing 80 \text{ mm}$ (fig. 10c)

The fumes outlet duct can be aimed in the most suitable direction for installation needs. To install follow the instructions supplied with the kit. In this configuration, the boiler is connected to the $\varnothing 80 \text{ mm}$ fumes outlet duct by means of a $\varnothing 60\text{-}80 \text{ mm}$ adaptor.

When necessary, the flue gas flange (A), must be removed or replaced using a screwdriver as a lever.

In this case, the combustion supporting air is taken from the room in which the boiler is installed, which must be a suitable and ventilated technical room.

Non-insulated fumes outlet ducts are potential sources of danger.

It is appropriate to install a condensate collector and specific pipes. In this case realize an inclination of 3° to the condensate collector.

Max length fumes outlet duct Ø 80 mm	Flue gas flange (Ø)	Load losses	
		45° bend	90° bend
up to 2	42	1,2m	1,7m
from 2 to 8	44 (*)		
from 8 to 25	not installed		

(*) fitted in boiler

“SEALED” INSTALLATION (TYPE C)

The boiler must be connected to concentric or twin fumes discharge and air intake ducts which must both be taken outside. Do not use the boiler without them.

Concentric outlets (Ø 60-100, fig. 10d)

The concentric outlets can be placed in the most suitable direction according to room requirements.

For installation, follow the instructions supplied with the kit.

When necessary, the flue gas flange (A), must be removed or replaced using a screwdriver as a lever.

⚠ It is appropriate to install a condensate collector and specific pipes. In this case realize an inclination of 3° to the condensate collector.

Max linear length concentric duct Ø 60-100 mm	Flue gas flange (Ø)	Load losses	
		45° bend	90° bend
up to 0,85	42	1m	1,5m
from 0,85 to 2,35	44 (*)		
from 2,35 to 4,25	not installed		

(*) fitted in boiler

Concentric outlets (Ø 80-125, fig. 10e)

The boiler has been designed to be connected to concentric outlet/suction pipes and with the opening for air suction closed.

The concentric outlets can be placed in the most suitable direction according to room requirements, complying with the maximum lengths indicated in the table.

For installation, follow the instructions supplied with the kit.

To go through the wall, drill a hole of Ø 130 mm.

According to the length of the pipes used, it is necessary to insert a flange as long as the boiler.

Pay special attention to external temperature and pipe length. Refer to the diagrams in order to establish if it is compulsory or not to use a condensation collector. In case of operation at temperature lower than 60 °C, it is compulsory to use a condensation collector. If a condensation collector is used, provide a slope of the flue exhaust pipe of 3° towards the collector.

Connect the condensation trap syphon to a white water outlet pipe.

Non insulated outlet pipes are potential sources of danger.

Max linear length concentric duct Ø 80-125 mm	Flue gas flange (Ø)	Load losses	
		45° bend	90° bend
from 0,96 to 3,85	42	1,35m	2,2m
from 3,85 to 7,85	44 (*)		
from 7,85 to 12,4	not installed		

(*) fitted in boiler

Fastech 24 KIS - reduced concentric bend

⚠ If it is necessary to install the boiler on systems already existing (replacement types Caldariello KIS), there is a “reduced concentric bend kit” available that allows positioning the boiler by keeping the same flue gas hole.

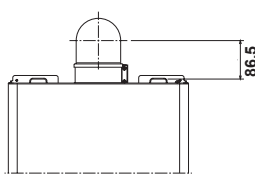

Pipe length with reduced bend (m)	Flue gas flange (A)	Load losses for each bend (m)	
		45°	90°
up to 1,85	Ø 44 (**)	1	1,5
from 1,85 to 4,25	not installed		

Twin outlets (Ø 80, fig. 10f)

Twin outlets can be placed in the most suitable direction according to the room requirements.

Remove the closure plug secured with the screws and use the specific adaptor for the combustion air intake pipe (E).

⚠ The air inlet adaptor Ø 80 (E) must be correctly directed, it is necessary to fasten it with the appropriate screws, so that the positioning flap does not interfere with the shell.

When necessary, the flue gas flange (A), must be removed using a screwdriver as a lever. The table indicates the permitted linear lengths. According to the length of the pipes used, it is necessary to insert a flange, selecting one from those contained in the boiler.

⚠ It is appropriate to install a condensate collector and specific pipes. In this case realize an inclination of 3° to the condensate collector.

Max length twin duct Ø 80 mm	Flue gas flange (Ø)	Load losses	
		45° bend	90° bend
up to 2 + 2	42	1,2m	1,7m
from 2 + 2 to 6 + 6	44 (*)		
from 6 + 6 to 16 + 16	not installed		

(*) fitted in boiler

POSSIBLE OUTLET CONFIGURATIONS (fig. 10a)

- B22P-B52P** Suction indoors and discharge outdoors.
- C12-C12x** Discharge via concentric wall outlet. The pipes may leave the boiler independently, but the outlets must be concentric or sufficiently close together to be subjected to similar wind conditions (within 50 cm).
- C22** Discharge via concentric outlet in common smoke pipe (suction and discharge in the same pipe).
- C32-C32x** Discharge via concentric roof outlet. Outlets as for C12.
- C42-C42x** Discharge and suction in common separate smoke pipes, but subjected to similar wind conditions.
- C52-C52x** Separate discharge and suction lines on wall or roof and in areas with different pressures. The discharge and suction lines must never be positioned on opposite walls.
- C82-C82x** Discharge via single or common smoke pipe and wall suction line.
- C92-C92x** Discharge on roof (similar to C32) and air suction from a single existing smoke pipe.

3.11 System filling and emptying (fig. 11)

Once the hydraulic connections have been made, the system can be filled.

FILLING

- Open the automatic air vent valve cap by two or three turns (A).
- Ensure that the cold water inlet valve is open.
- Open the filling tap (B) until the pressure on the hydrometer is between 1 and 1.5 bar.
- Close the filling tap.

NOTE: air in the boiler is bled automatically via the automatic air vent valve on the pump. Ensure that the valve of the air vent valve is open.

EMPTYING

Before emptying, disconnect the electric power supply by switching the main system switch to “OFF”.

Close the cold water inlet valve.

a) Heating system:

- Close all shut-off devices of the heating circuit.
- Connect the pipe supplied as standard to the discharge valve (C).
- Loosen the discharge valve (C).

b) DHW system:

- Open the hot and cold water utility valves and empty from the lowest points.

⚠ The safety valve outlet (D) must be connected to a suitable disposal system. The manufacturer declines all liability for any flooding caused by the safety valve.

4 - COMMISSIONING AND MAINTENANCE

4.1 Preparation for initial commissioning

Before turning on and testing the boiler for the first time, check that:

- the system gas and water valves are open

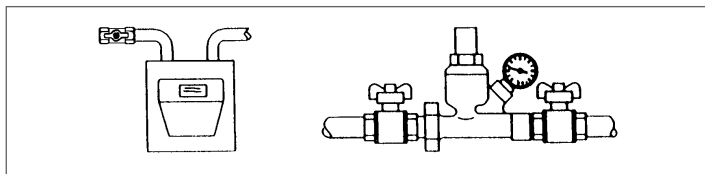

- the type of gas and the supply pressure comply with the boiler specifications
- the vent valve cap is open
- the hydraulic circuit pressure, when cold, is between 1 and 1.5 bar and the circuit is de-aerated
- preloading of the expansion tank is adequate (refer to the data table)
- the electrical connections have been made correctly
- the flue gas discharge ducts and the combustion air suction vents have been fitted correctly
- the pump can rotate freely: unscrew the inspection screw and use a slotted screwdriver to check that the rotor shaft moves freely.

Before loosening or removing the pump cap, protect the electric devices underneath from any leaks.

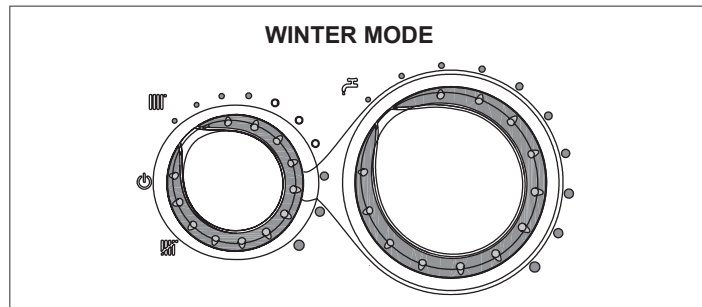

Heating water temperature adjustment

To adjust the temperature of the heating water, turn the function selector within the adjustment range (clockwise to increase and anti-clockwise to decrease).

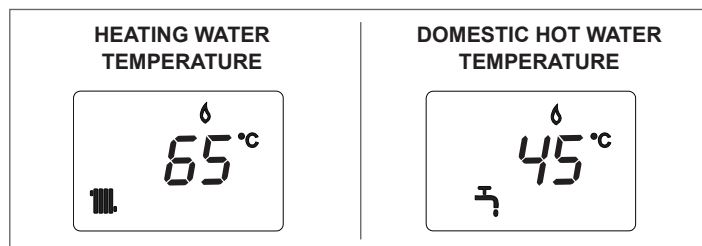

SUMMER: by turning the function selector to the Summer symbol , the conventional DHW-only function is activated. In the event of a DHW request, the boiler turns on. The digital display indicates the domestic hot water temperature.

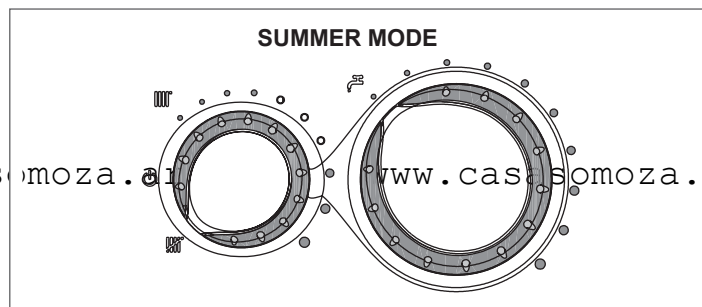

DHW temperature adjustment

To adjust the domestic hot water temperature (bathrooms, showers, kitchens, etc.), turn the dial with the symbol  clockwise to increase the value, or anti-clockwise to decrease (min. value 37 °C - max. value 60 °C). The boiler remains on standby until the burner ignites following a heat request. The boiler operates until the controlled temperatures are reached or the heat demand is met, after which it returns to standby status. In the case of a temporary stop, the digital display shows the code associated with the fault that has occurred.

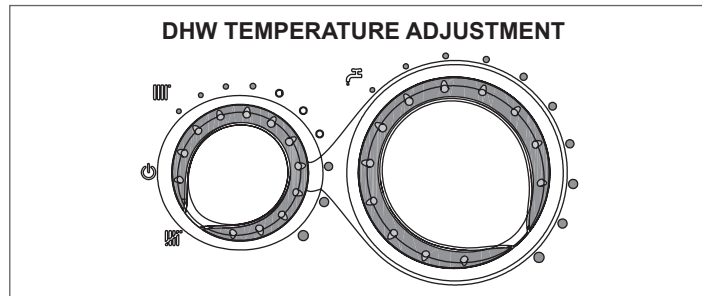

Heating Temperature Control function (C.T.R.)

When the heating water temperature selector is positioned in the sector indicated in the figure, the C.T.R. self-control function is activated. According to the temperature set on the room thermostat and the time taken to reach this value, the boiler automatically varies the heating water temperature, reducing operating time and enabling increased comfort and energy savings.

FASTECH KI

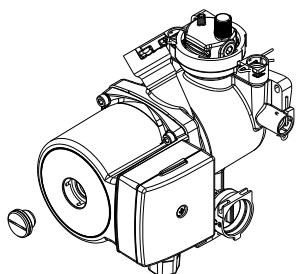

FASTECH KIS

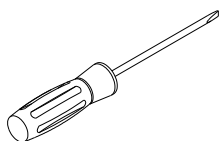
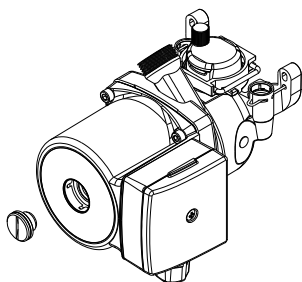

4.2 First start-up

To turn on the boiler:

- Connect the boiler to the mains
- Open the gas valve, to enable the gas supply
- Adjust the room thermostat to the desired temperature (~20°C)

Turn the function selector to the required setting:

WINTER: when the function selector is set to within this range, the boiler supplies domestic hot water and heating. In the event of a heating request, the boiler turns on.

The digital display indicates the heating water temperature. In the event of a DHW request, the boiler turns on. The display indicates the temperature of the domestic hot water.

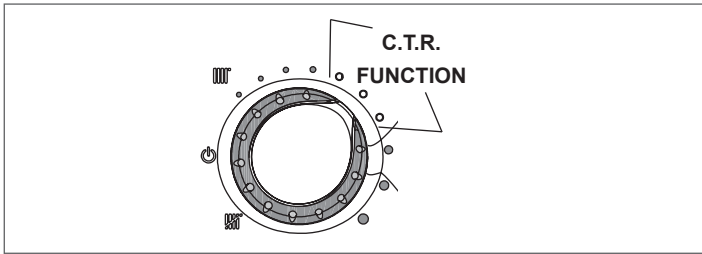

Unblock function

To restore operation, turn the function selector to OFF, wait 5-6 seconds and then set the function selector to the required position. The boiler restarts automatically.

NOTE: if the unblock attempts do not restart the boiler, contact the Technical Support Centre.

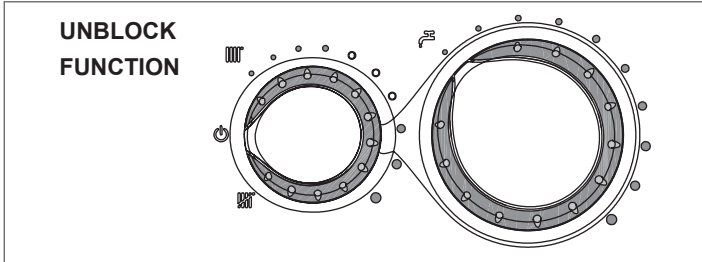

4.3 Checks during and after commissioning

After commissioning, ensure that the **FASTECH** boiler runs the start-up and subsequent shutdown procedure correctly using the:

- function selector
- calibration of the heating water temperature selector and DHW temperature selector
- required room temperature (adjusting the room thermostat or timer).

Check operation in DHW mode by opening a hot water tap with the function selector set to Summer mode and to Winter mode.

Check that the boiler stops completely when turning the main system switch to "OFF".

Operate the appliance continuously for a few minutes by turning the main switch to "ON" setting the function selector to Summer and Winter mode and keeping the DHW utility tap on. The processing binders and residue evaporate and the following can be checked:

- supply gas pressure
- combustion.

Supply gas pressure check

- Turn the main system switch to "OFF".
- Unscrew the case screws (A).

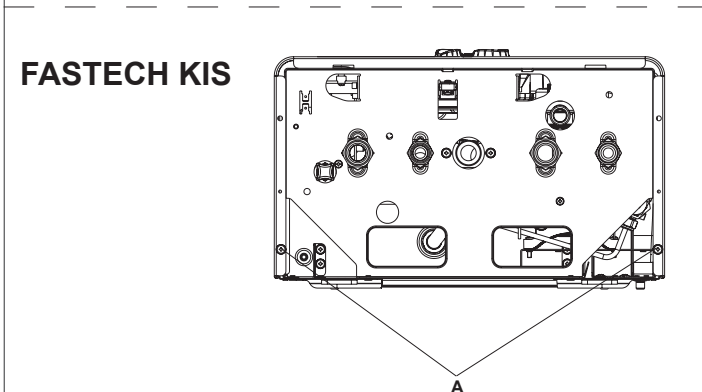
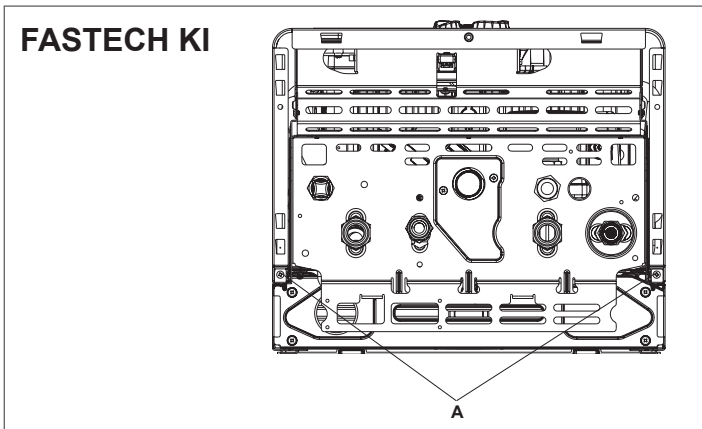

- Move the bottom of the case forward and then upwards to detach it from the frame.
- Unscrew the panel screws (B).
- Turn the control panel forwards.

FASTECH KI

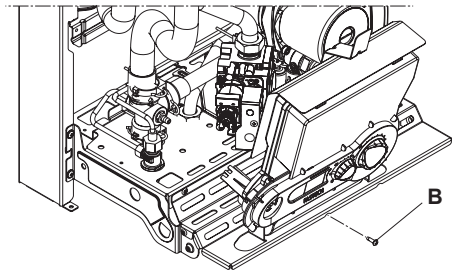

FASTECH KIS

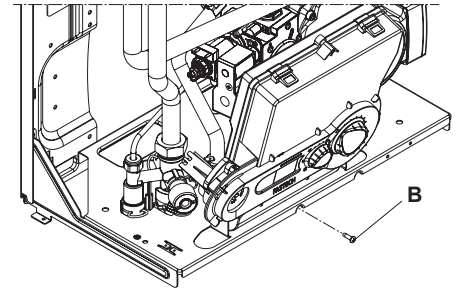

- Unscrew the tapping point screw upstream of the gas valve by approximately two turns and connect a pressure gauge.

On the control panel:

- set the function selector to "Summer mode" and the DHW temperature selector to the maximum

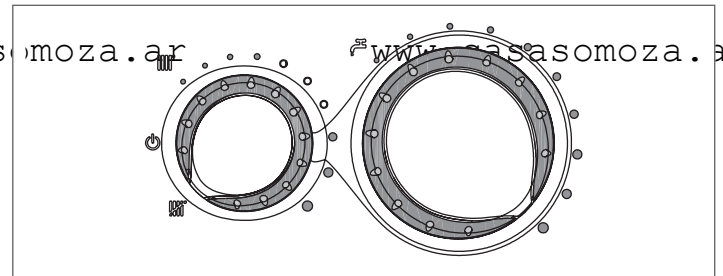

- turn the boiler on by setting the main switch to "ON"
- open the hot water cock to the maximum flow rate
- with the burner lit at the maximum output, check that the gas pressure is between the minimum and the nominal supply values as specified in the multigas table
- turn off the hot water tap
- disconnect the pressure gauge and tighten the pressure tapping point upstream of the gas valve.

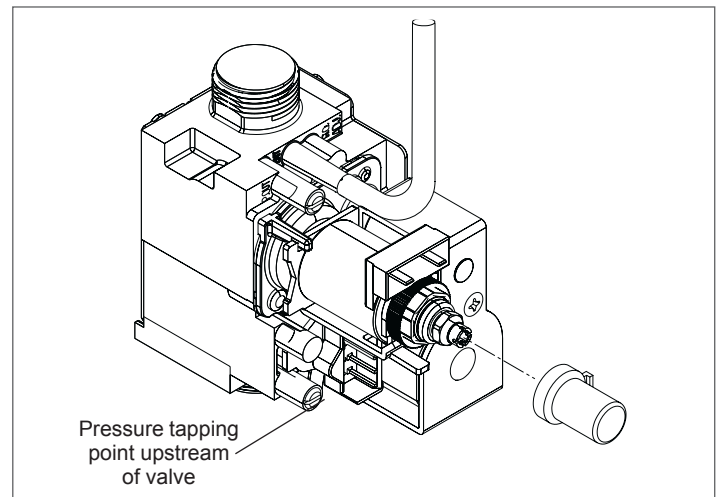

Combustion check

FASTECH KI

- Install the "Flue analysis collection" kit in the straight pipe section after the hood output, at least 400-500 mm from the hood (as envisaged by current standards). To install, follow the instructions supplied with the kit.
- Turn the main system switch to "OFF".
- Set the function selector to "Summer mode" and the DHW temperature selector to the maximum.
- Turn the boiler on by setting the main switch to "ON".
- Open the hot water tap to the maximum flow rate.
- With the boiler at the maximum output, you can check combustion.

FASTECH KIS

- Open the hot water tap to the maximum flow rate.
- Set the function selector to "Summer mode" and the DHW temperature selector to the maximum.
- Turn the boiler on by setting the main switch to "ON".
- With the boiler at the maximum output, you can check combustion.

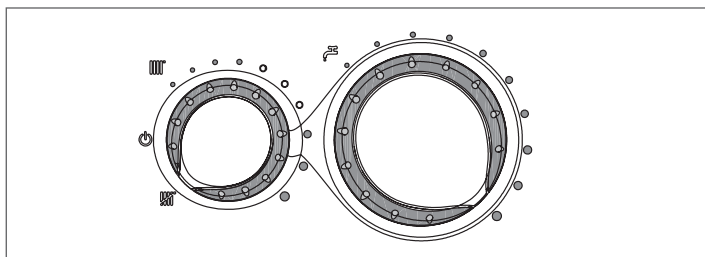

- On completion of the check, shut off the hot water tap.
- Remove the tester sensor and close the test point.
- Close the panel and refit the case, following the disassembly procedure described above in reverse order.

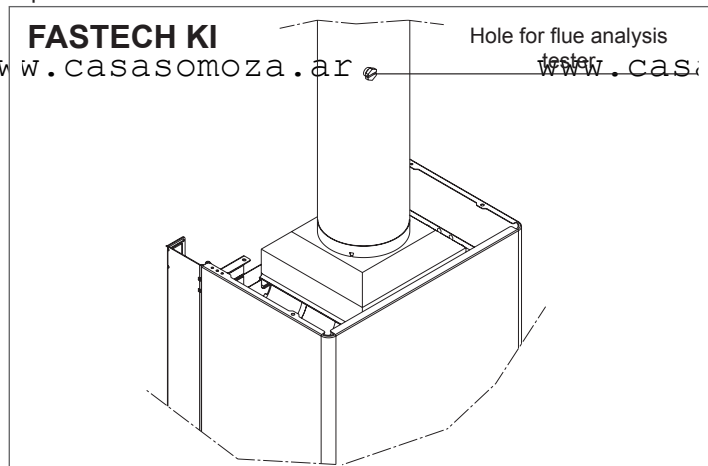

FASTECH KIS

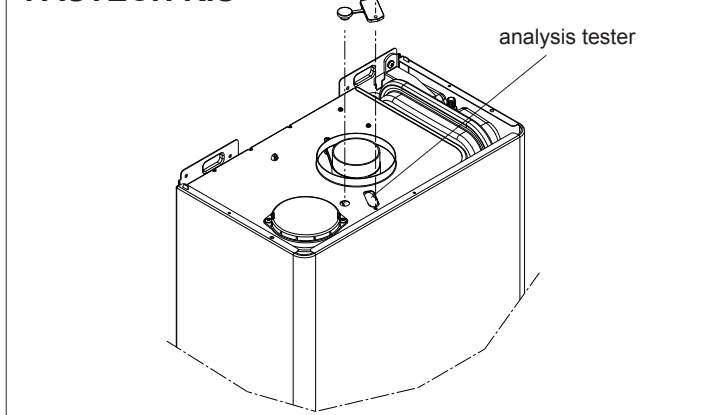

At the end of the checks:

- set the function selector to "Summer mode" or "Winter mode" according to the current time of year
- adjust the selectors as required by the client.

! The **FASTECH** boiler is supplied to operate with natural gas and can be converted for use with LPG. It has been factory set as specified on the technical data plate and does not require any calibration.

! All checks and inspections must be carried out exclusively by the Technical Assistance Service.

4.4 Display and fault codes

BOILER STATUS	DISPLAY	ALARM TYPE
OFF status	OFF	None
Stand-by	-	Warning
ACF module block alarm	A01	Permanent block
ACF electronics fault alarm	A02	Permanent block
Limit thermostat alarm	A03	Permanent block
Fumes thermostat alarm (KI)	A04	Permanent block
Differential air pressure switch alarm (KIS)	A06	Warning
Water pressure switch alarm	A07	Temporary stop
DHW NTC fault	A07	Temporary then permanent
NTC fault (heating)		Permanent block
Heating delivery sensor over-temperature	A11	Temporary stop
Delivery/return sensor differential alarm	A77	Temporary stop
Parasite flame	80°C (flashing)	Temporary stop
Low temperature systems thermostat alarm		Temporary stop
Transitory awaiting ignition	ADJ	Warning
Water pressure switch trip	60°C	Warning
Service calibration	80°C	Warning
Installer calibration		Warning
External sensor detected		Warning
DHW request		Warning
Heating request		Warning
Anti-freeze heat request		Warning
Flame detected		Warning

To restore operation (unblock alarms):

Faults A01-02-03

Set the function selector to OFF , wait 5-6 seconds and return to the required setting.
If the unblock attempts do not reactivate the boiler, please request support from the Technical Assistance Service.

Fault A04

The digital display shows the fault code together with the symbol . Check the pressure shown on the water gauge: if the pressure is less than 0.3 bar, set the function selector to (OFF) and adjust the filling valve until the pressure is between 1 and 1.5 bar. Turn the function selector back to the required setting.

If there are frequent drops in pressure, please request support from the Technical Assistance Service.

Fault A06

The boiler operates normally but does not guarantee a stable domestic hot water temperature, which is set to around 50°C. Please request support from the Technical Assistance Service.

Fault A07

Please request support from the Technical Assistance Service.

4.5 Temporary shutdown

During temporary absences, weekends, short holidays etc., set the function selector to **OFF**.

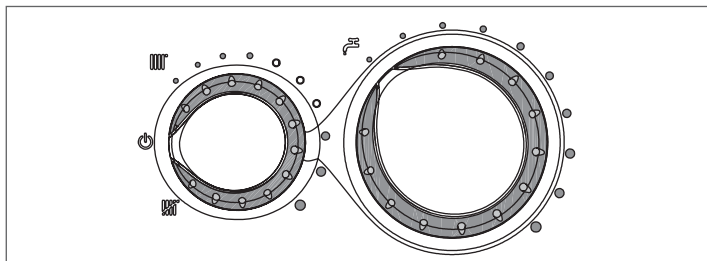

With the power mains ON and the gas supply active, the boiler is protected by the systems:

- Anti-freeze

This function is activated if the boiler water temperature falls below 5°C. The pump runs a 15 minute cycle every 2 hours as follows: the pump stops when the boiler water temperature exceeds 10°C; the burner is ignited to the minimum in heating mode when the boiler water temperature falls below 5°C until the water temperature reaches 30°C, after which a post-pump phase runs for 30 seconds.

- Pump anti-block function

The pump is activated every 24 hours of standby and, in any event, 3 hours after the last DHW request.

4.6 Shutdown for long periods

If the **FASTECH** boiler will not be used for a long period of time:

- set the function selector to **OFF** (OFF-unblock)
- turn the main system switch to "OFF"
- close the heating and domestic hot water system gas and water cocks.

! The anti-freeze and pump anti-block functions are disabled.

! Empty the heating and DHW circuit if there is a risk of freezing.

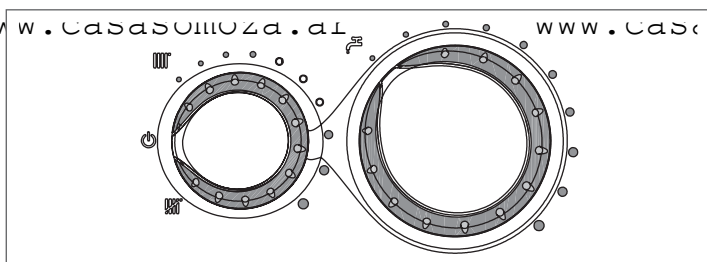

4.7 Maintenance

Periodic maintenance is an "obligation" required by law and is essential to the safety, efficiency and lifetime of the boiler. It allows for the reduction of consumption, polluting emissions and keeping the product reliable over time.

Before starting maintenance operations:

- Perform the analysis of the combustion products to check the boiler operation status then cut the electrical supply by turning off the system's general switch
- Close the fuel and water taps of the heating and domestic hot water system.

The appliance must be systematically controlled at regular intervals to make sure it works correctly and efficiently and conforms to legislative provisions in force.

The frequency of controls depends on the conditions of installation and usage, it being anyhow necessary to have a complete check carried out by authorized personnel from the Servicing Centre every year.

- Check and compare the boiler's performance with the relative specifications. Any cause of visible deterioration must be immediately identified and eliminated.

- Closely inspect the boiler for signs of damages or deterioration, particularly with the drainage and aspiration system and electrical apparatus.
- Check and adjust – where necessary – all the burner's parameters.
- Check and adjust – where necessary – the system's pressure.
- Analyze combustion. Compare results with the product's specification. Any loss in performance must be identified and corrected by finding and eliminating the cause.
- Make sure the main heat exchanger is clean and free of any residuals or obstruction; if necessary clean it.
- Check and clean – where necessary – the condensation tray to make sure it works properly.

! Always switch off the power to the appliance and close the gas by the gas cock on the boiler before carrying out any maintenance and cleaning jobs on the boiler.

! After performing the necessary maintenance operations, the original adjustments must be restored and the combustion product analysis must be performed to check the correct operation.

! Do not clean the appliance or any latter part with flammable substances (e.g. petrol, alcohol, etc.).

! Do not clean panelling, enamelled and plastic parts with paint solvents.

! Panels must be cleaned with ordinary soap and water only

4.8 Adjustments

FASTECH boilers are supplied for operation with natural gas and are factory-set as specified on the technical data plate.

However, if it is necessary to repeat the adjustments, for example after non-scheduled maintenance, replacing the gas valve or after conversion from natural gas to LPG, or vice versa, proceed as described below.

The minimum and maximum output and the maximum heating settings must be set in the specified sequence and exclusively by qualified technicians.

- Turn the main system switch to "OFF".
- Remove the case unscrewing the **twisting screw**.
- Unscrew the panel screw and turn the control panel forwards.
- Unscrew the tapping point screw downstream of the gas valve by approximately two turns and connect a pressure gauge.
- Disconnect the compensation tube from the air chamber (only KIS model).

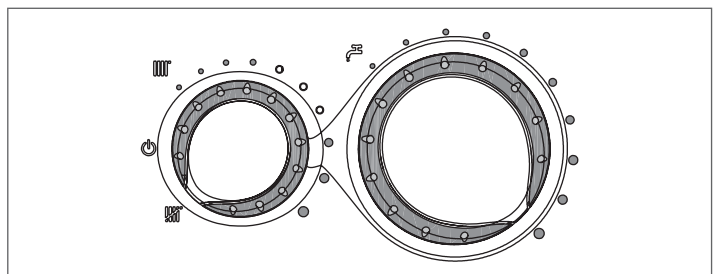
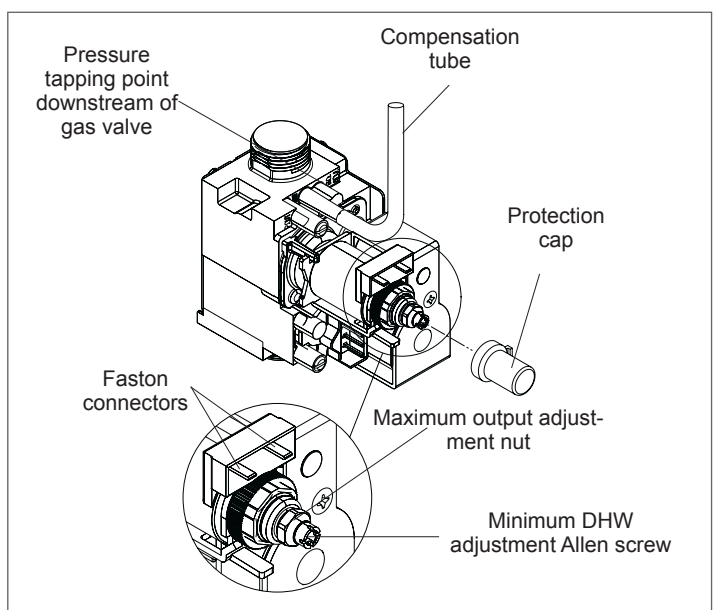

Maximum and minimum DHW output setting

- Open the hot water tap to the maximum flow rate.
- On the control panel, set the function selector to ☀️ “Summer mode” and set the DHW temperature selector to the maximum.
- Turn the boiler on by setting the main switch to “ON”.
- Check that the pressure reading on the gauge is stable. If the reading is not stable, use a milli-ammeter (in series with a modulator wire) to check that the maximum available current is delivered to the modulator (120 mA for G20, and 165 mA for LPG).
- Remove the protection cap from the adjustment screws carefully using a screwdriver.
- Using a fork wrench CH10, turn the adjustment nut for maximum output to obtain the value specified in **table 1**.

TABLE 1

Maximum pressure downstream of valve (tolerance ±10%)	NATURAL GAS (G20)	LIQUID GAS		
		BUTANE (G30)	PROPANE (G31)	
FASTECH 24 KI	10,10	28,00	35,50	mbar
FASTECH 24 KIS	11,80	27,80	35,80	mbar

- Disconnect a faston clamp from the modulator.
- Wait for the pressure on the gauge to stabilise at the minimum value.
- Use a hex wrench – taking care not to press the internal shaft – to adjust the red screw for the DHW minimum setting and calibrate until the gauge shows the value specified in **table 2**.

TABLE 2

Minimum pressure downstream of valve (tolerance ±10%)	NATURAL GAS (G20)	LIQUID GAS		
		BUTANE (G30)	PROPANE (G31)	
FASTECH 24 KI	1,20	3,50	4,60	mbar
FASTECH 24 KIS	1,50	3,30	4,30	mbar

- Reconnect a faston clamp on the modulator.
- Close the domestic hot water tap.

Electrical setting of minimum and maximum heating

⚠️ The “electrical setting” function is activated and deactivated exclusively via the jumper (JP1).

The function can be enabled by:

- powering up the board with jumper JP1 wired in, and the function selector set to Winter, regardless of whether other operating requests are active or not
- wiring in jumper JP1, with the function selector set to Winter, without any heating requests in progress.

⚠️ Activating the function involves starting up the burner by simulating a heating request.

To calibrate:

- turn the boiler off
- remove the case and rotate the panel

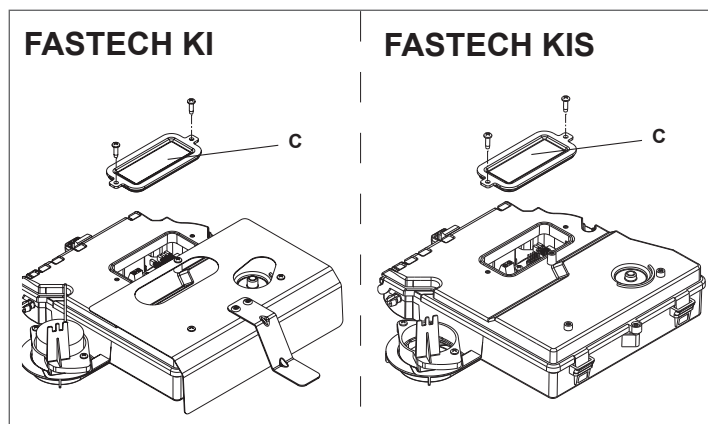

- unscrew the screws to access the board
- wire in jumper JP1 to enable the dials on the control panel for setting the minimum and maximum heating values.
- ensure that the function selector is set to Winter
- connect the boiler to the mains

⚠️ Electrical board powered (230 V).

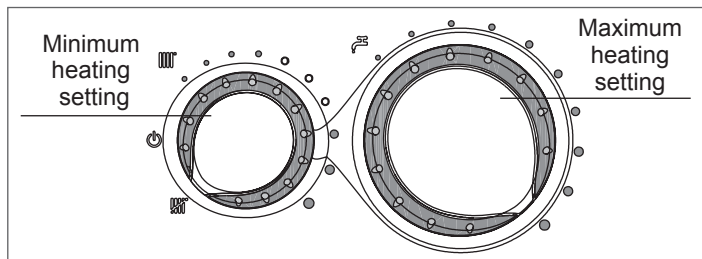

- Turn the heating water temperature dial to the minimum heating value as specified in **table 3**

TABLE 3

Minimum pressure in heating mode downstream of valve (tolerance ±10%)	NATURAL GAS (G20)	LIQUID GAS		
		BUTANE (G30)	PROPANE (G31)	
FASTECH 24 KI	1,90	5,60	7,30	mbar
FASTECH 24 KIS	1,50	3,30	4,30	mbar

- Wire in jumper JP2
- Turn the DHW temperature adjustment dial to the maximum heating value as specified in **table 4**.

TABLE 4

Maximum pressure in heating mode downstream of valve (tolerance ±10%)	NATURAL GAS (G20)	LIQUID GAS		
		BUTANE (G30)	PROPANE (G31)	
FASTECH 24 KI	10,10	28,00	35,50	mbar
FASTECH 24 KIS	11,80	27,80	35,80	mbar

- Remove jumper JP2 to memorise the maximum heating value
- Remove jumper JP1 to memorise the minimum heating value and to exit the calibration procedure
- Connect the compensation tube to the air chamber (only KIS model)
- Disconnect the pressure gauge and refit the tapping point screw.

www.casasomoza.ar

www.casasomoza.ar

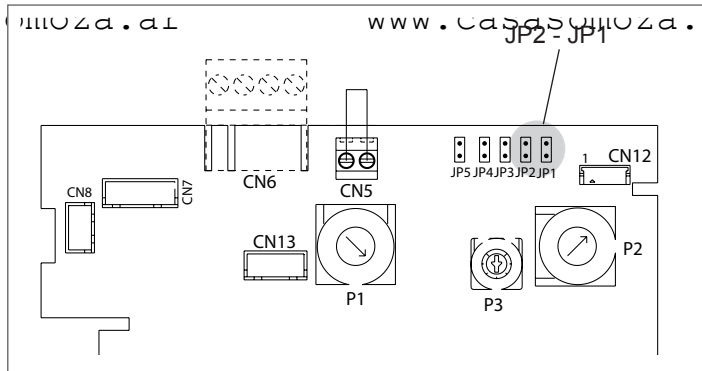

- ⚠️ To terminate calibration without memorising the set values either:
 - a) set the function selector to ⏻ (OFF-unblock)
 - b) turn off the power supply.

⚠️ Calibration is completed automatically, without memorising the minimum or maximum values, 15 minutes after activation.

⚠️ The function is also terminated automatically in the event of a shutdown or permanent block. Again, values are NOT memorised.

NOTE: to calibrate only the maximum heating value, remove jumper JP2 (to memorise the maximum value) and then exit the function without memorising the minimum value by setting the function selector to ⏻ OFF or by turning the boiler off at the mains.

⚠️ After any intervention on the gas valve adjustment component, seal with sealing paint.

4.9 Converting from one gas type to another

The boiler is supplied to operate with natural gas according to the specifications on the technical data plate.

However, it may be converted from one type of gas to another by using the special kits available on request.

- Natural gas conversion kit
- LPG conversion kit

- ⚠ This conversion procedure must only be carried out by the Technical Assistance Service or by personnel authorised, also once the boiler has been installed.
- ⚠ For information on assembly, please refer to the instructions supplied with the kit.
- ⚠ After converting the boiler, it must be adjusted again. Follow the instructions in the relevant paragraph and apply the new identification data plate supplied in the kit.

- ⚠ Use and fit the washers supplied in the kit only, even for manifolds without washers.
- Refit the burner in the combustion chamber and tighten the screws securing it to the gas manifold
- **FASTECH KIS**: position the cable gland with the spark plug wires on the air chamber
- Reconnect the spark plug wire
- Refit:
 - FASTECH KI**: combustion chamber cover and the lower shell
 - FASTECH KIS**: combustion chamber cover and air chamber cover
- Turn the control panel forwards
- Remove the cover (C) to access the control board

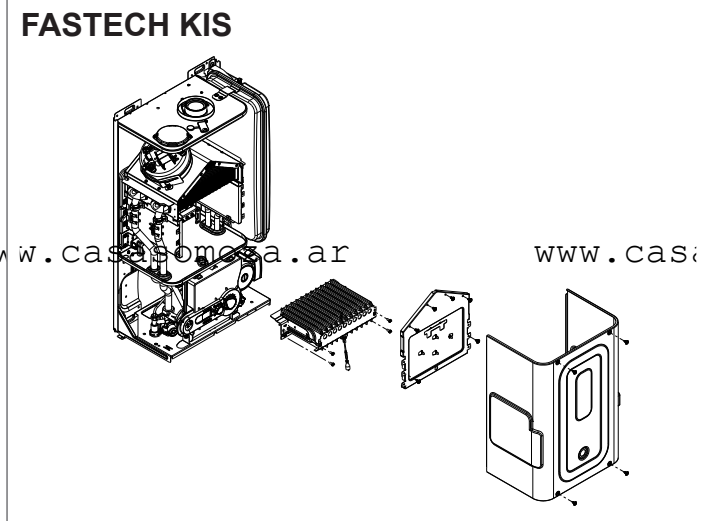
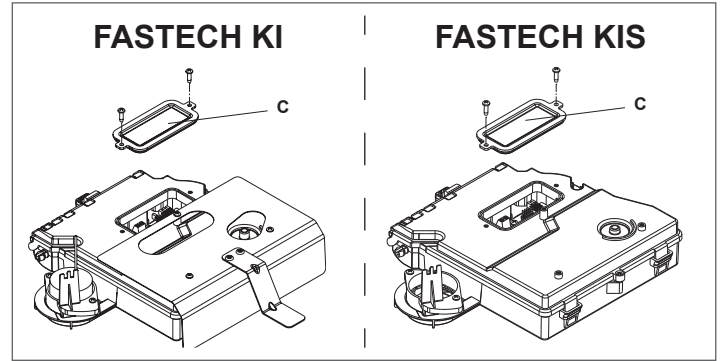
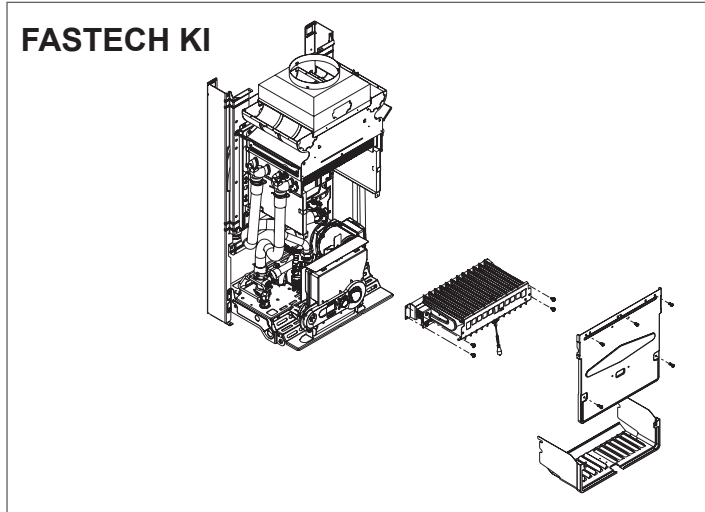

- To convert from natural gas to LPG:** wire the jumper in position JP3.
- To convert from LPG to natural gas:** remove the jumper from position JP3.
- Turn the boiler on again and reopen the gas valve.
- Adjust the boiler as explained in the chapter "Adjustments". This must be done exclusively by the Technical Assistance Service.
- Close the cover.
- Apply the adhesive gas identification label supplied in the kit, to replace the previous version.
- Refit the case.

- If converting from natural gas to LPG:**
- Turn off the power to the boiler and shut off the gas valve
 - Remove the following in sequence:
 - FASTECH KI**: case, lower shell and combustion chamber cover
 - FASTECH KIS**: case, air chamber cover and combustion chamber cover
 - Disconnect the spark plug wire
 - **FASTECH KI**: unscrew the burner screws and remove the burner with the spark plug attached
 - **FASTECH KIS**: remove the cable gland from the air chamber, unscrew the burner screws and remove the burner with the spark plug and cables attached
 - Using a box spanner or fork wrench, remove the nozzles and washers and replace them with those supplied in the kit

- 4.10 Boiler cleaning**
- Before cleaning, disconnect the electric power supply by switching the main system switch to "OFF".
- External cleaning**
- Clean the casing, the control panel, the painted parts and the plastic parts with damp, soapy cloths. For stubborn stains, dampen the cloth with a 50% water and denatured alcohol mixture, or use specific products.
- ⊘ Never use fuel and/or sponges soaked in abrasive solutions or powder detergents.
- Internal cleaning**
- Before cleaning the inside:
- shut off the gas valves
 - close the system taps.

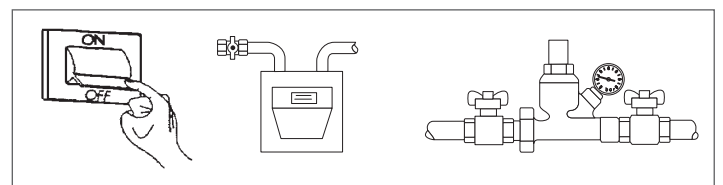
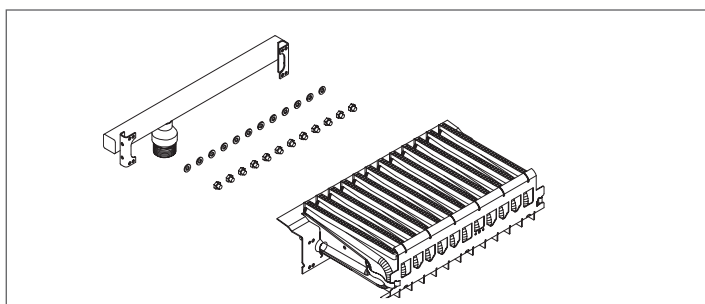

USER

A - General instructions

! When you receive the product, make sure that it is integral and complete with all its parts. If it does not correspond with the order, please contact the Riello Agency that sold the appliance.

! The boiler must be installed by a qualified company. Once the appliance has been installed, this company must issue the owner with an installation declaration of conformity, certifying that the installation has been performed professionally, in compliance with all national and local regulations in force, and with the Riello instruction manual supplied with the appliance.

! The **FASTECH KI** boiler must be used for the purpose for which it was designed and produced by the manufacturer. Riello does not accept any contractual or extra-contractual liability for damage caused to people, animals or property, due to incorrect installation, setting, or maintenance, or due to improper use.

! In the event of a water leak, disconnect the boiler from the electric mains supply, shut-off the water supply and promptly notify the Technical Assistance Service or a professionally qualified technician.

! Periodically check that the operating pressure of the water supply system is above 1 bar and below the maximum limit specified for the appliance. If this is not the case, please contact the Technical Assistance Service or a professionally qualified technician.

! **FASTECH KI** boilers are equipped with a fumes thermostat positioned on the right side of the hood. If combustion products are returned, this device immediately shuts down operation of the boiler.

! If the fumes thermostat is tripped, there is a boiler fault. Please contact the Technical Assistance Service immediately.

! If the boiler will not be used for a prolonged period of time, you must:

- turn the main appliance switch to "OFF"
- turn the main system switch to "OFF"
- shut off the heating system gas and water cocks
- empty the heating system and the domestic hot water (DHW) system if there is a risk of freezing.

! Boiler maintenance is to be carried out at least once a year.

! This manual and the Installer and Technical Assistance Service manual are an integral part of the device and therefore should be carefully preserved and must always accompany the boiler even in the event of its sale to another owner or user or transfer to another facility. If lost or damaged, please request another copy from the Technical Assistance Service for your area.

! The pump anti-block function is activated after 24 hours of inactivity, with the function selector on any setting.

! For information on installation, please contact specialist technicians.

! The air vents are essential for correct combustion and for safety (only KI model).

! At the end of its lifetime, the product must not be disposed of as solid urban waste but must be delivered to a specialised waste disposal centre for recycling.

B - Basic safety rules

Please remember that in using products which involve gas, electricity and water, you must adhere to some basic safety requirements:

⊖ Do not operate electrical devices or appliances such as switches or domestic appliances, etc. if you can smell gas or unburned gas. Should this occur:

- open the doors and windows to ventilate the room;
- close the gas shut-off device;
- call the Technical Assistance Service immediately, or a professionally qualified technician.

⊖ Do not touch the appliance when barefoot or with any wet parts of the body.

⊖ Disconnect the appliance from the mains power supply before carrying out any technical intervention or cleaning the appliance. To disconnect the appliance, turn the main system switch to "OFF" and the main boiler switch to "OFF".

⊖ Do not modify the safety or adjustment devices without prior authorisation or instructions from the manufacturer.

⊖ Do not pull, disconnect or twist the electrical cables coming from the appliance, even if the appliance is disconnected from the mains electricity supply.

⊖ Do not seal off or reduce the size of the air vents in the room where the boiler is installed. The air vents are essential for correct combustion.

⊖ Do not expose the appliance to weathering. It is not designed to operate outdoors.

⊖ Do not leave containers of flammable substances in the room where the boiler is installed.

⊖ This appliance may not be used by persons (including children) with reduced physical, sensorial or mental ability or by those with little experience or knowledge of this device, unless they are supervised or trained by the person responsible for its use in complete safety.

⊖ Dispose of packaging responsibly and keep all packaging material out of the reach of children, as this is a potential source of danger. The packaging material is to be disposed of in accordance with applicable laws.

⊖ Do not disconnect the boiler from the electrical mains or shut off the gas valve if the temperature could fall below zero, as the first level anti-freeze system (see "Temporary shutdown") would be disabled.

⊖ Do not modify sealed components.

⊖ Do not place potentially hazardous objects on the boiler.

C - Commissioning

The boiler should be started up the first time by the Technical Assistance Service, after which the boiler can operate automatically. However, you may need to start up the boiler again at a later date without involving the Technical Service, for example after a long period of absence.

In these cases:

- Ensure that the heating and domestic hot water system gas and water cocks are open.

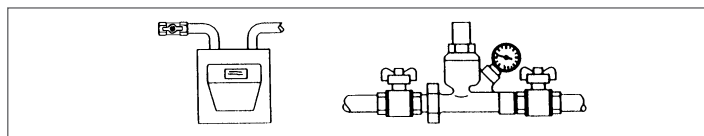

- Check the operating status of the filtering and/or water treatment devices.
- Ensure that the water circuit pressure, in cold conditions, is always between 1 and 1.5 bar.
- Adjust the room thermostat to the required temperature (~20°C) or, if the systems are equipped with a programmable thermostat or a timer, check that it is ON and set (~20°C).

Turn the function selector to the required setting:

Winter mode

When the function selector is set to within this range, the boiler supplies domestic hot water and heating. In the event of a heating request, the boiler turns on.

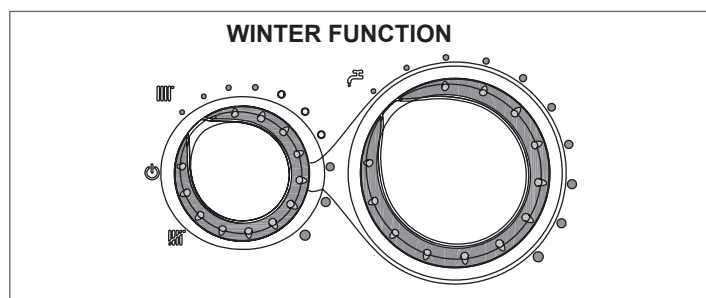

The digital display indicates the heating water temperature. In the event of a DHW request, the boiler turns on. The display indicates the temperature of the domestic hot water.

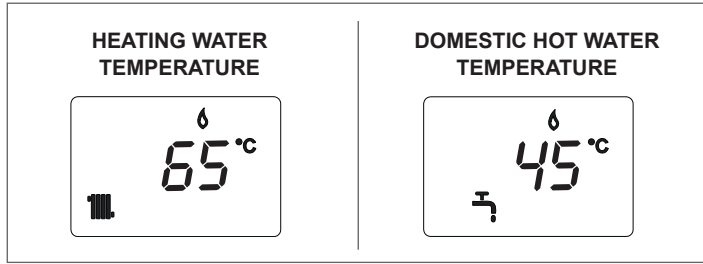

Summer mode

By turning the function selector to the Summer symbol ☀️, the conventional function of only DHW is activated. In the event of a DHW request, the boiler turns on. The digital display indicates the domestic hot water temperature.

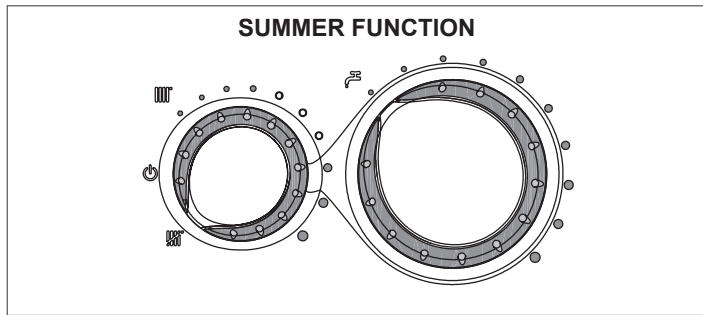

Heating Temperature Control function (C.T.R.)

When the heating water temperature selector is positioned in the sector indicated in the figure, the C.T.R. self-control function is activated. According to the temperature set on the room thermostat and the time taken to reach this value, the boiler automatically varies the heating water temperature, reducing operating time and enabling increased comfort and energy savings.

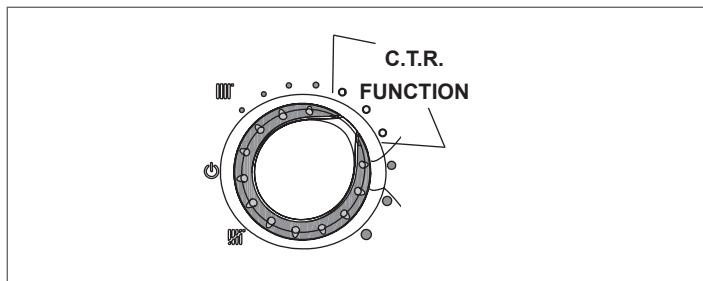

D - Heating temperature adjustment

To adjust the temperature of the heating water, turn the function selector within the adjustment range (clockwise to increase and anti-clockwise to decrease).

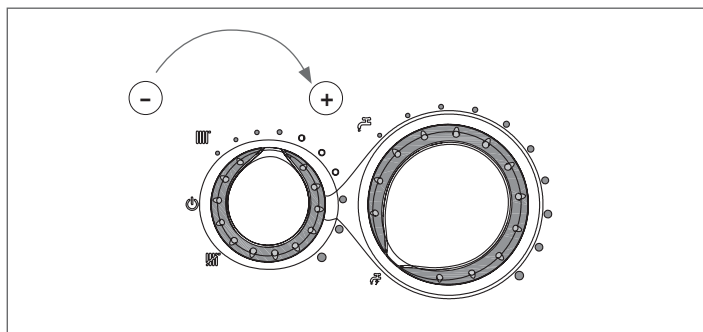

E - DHW temperature adjustment

To adjust the domestic hot water temperature (bathrooms, showers, kitchens etc.), turn the dial with the symbol 🚿:

- clockwise to increase the value;
- anti-clockwise to decrease the value (min. 37°C, max. 60°C).

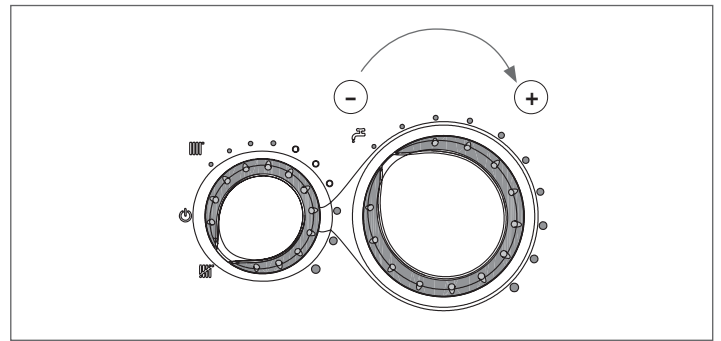

The boiler remains on standby until the burner ignites following a heat request.

The boiler operates until the controlled temperatures are reached or the heat demand is met, after which it returns to standby status.

F - Temporary shutdown

During temporary absences, weekends, short trips, etc.:

- set the function selector to ⏻ (OFF).

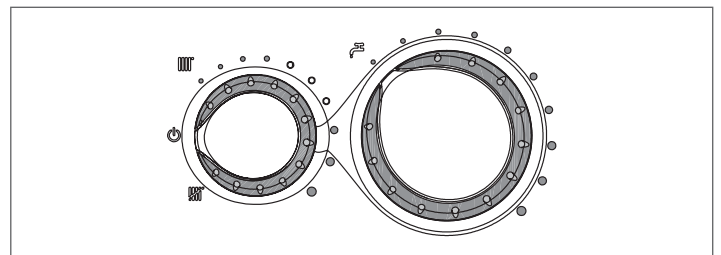

With the power mains connected and the gas supply active, the boiler is protected by the systems:

Anti-freeze

This function is activated if the boiler water temperature falls below 5°C. The pump runs a 15 minute cycle every 2 hours as follows: the pump stops when the boiler water temperature exceeds 10°C; the burner is ignited to the minimum in heating mode when the boiler water temperature falls below 5°C until the water temperature reaches 30°C, after which a post-pump phase runs for 30 seconds.

During the anti-freeze cycle, the ❄️ symbol is shown on the digital display.

Pump anti-block function

The pump is activated every 24 hours of standby and, in any event, 3 hours after the last DHW request.

G - Shutdown for long periods

If the boiler is not used for a long period of time, proceed as follows:

- set the function selector to ⏻ (OFF).
- turn the main system switch to "OFF".

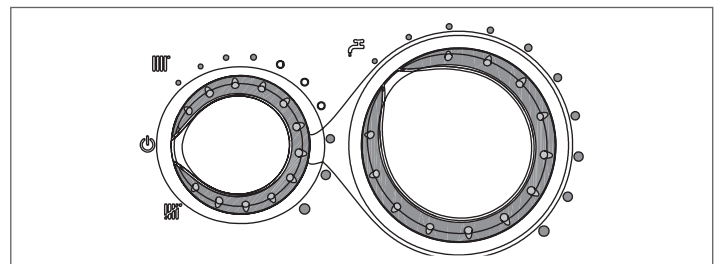

- close the heating and domestic hot water system gas and water cocks.

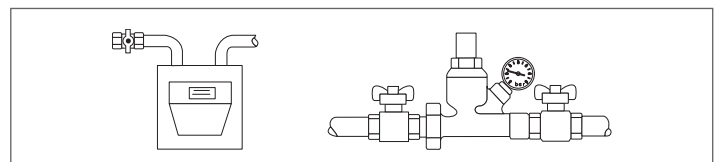

! In this case, the anti-freeze and pump anti-block functions are disabled. Empty the heating and DHW system if there is a risk of freezing.

! The Technical Assistance Service is available in the event of problems in carrying out the above procedure.

H - Display and fault codes

The boiler operating status is shown on the digital display. The different displays are listed below.

BOILER STATUS	DISPLAY	ALARM TYPE
OFF status	OFF	None
Stand-by	-	Warning
ACF module block alarm	A01 ✕ 🔔	Permanent block
ACF electronics fault alarm	A02 🔔	Permanent block
Limit thermostat alarm	A03 🔔	Permanent block
Fumes thermostat alarm (KI)	A04 👤 🔔	Permanent block
Differential air pressure switch alarm (KIS)	A06 🔔	Warning
Water pressure switch alarm	A07 🔔	Warning
DHW NTC fault	NTC fault (heating)	Temporary stop
Heating delivery sensor over-temperature	A07 🔔	Temporary then permanent
Delivery/return sensor differential alarm		Permanent block
Parasite flame	A11 🔔	Temporary stop
Low temperature systems thermostat alarm	A77 🔔	Temporary stop
Transitory awaiting ignition	80°C (flashing)	Temporary stop
Water pressure low alarm	👤 🔔 (flashing)	Temporary stop
Service calibration	ADJ 🔔	Warning
Installer calibration		Warning
External sensor detected	👤	Warning
DHW request	60°C 🔥	Warning
Heating request	80°C 🔥	Warning
Anti-freeze heat request	❄️	Warning
Flame detected	🔥	Warning

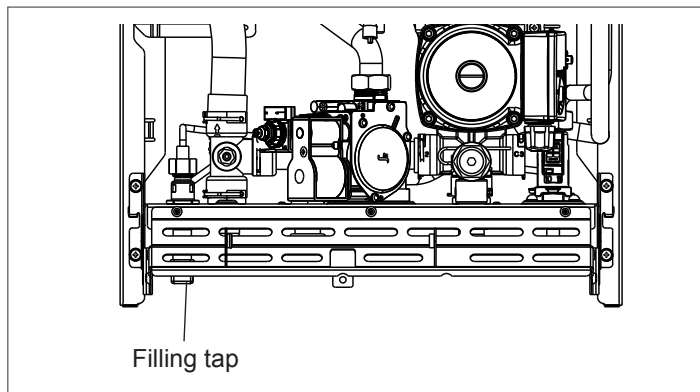

Then turn the function selector back to the required setting. If there are frequent drops in pressure, please request support from the Technical Assistance Service.

Fault A06

The boiler operates normally but does not guarantee a stable domestic hot water temperature, which is set to around 50°C.

Please request support from the Technical Assistance Service.

Fault A07

Please request support from the Technical Assistance Service.

J - Periodic scheduled maintenance

OPERATIONS	1st YEAR	2nd YEAR
Sealing component check	°	°
Flue-side primary exchanger cleaning	°	°
Water and gas safety device check	°	°
Gas flow rate check and adjustments where necessary	°	°
Flue duct and draught check	°	°
Burner cleaning and ignition efficiency check	°	°
Hydraulic efficiency check	°	°
Combustion analysis	-	°
Check and lubrication of hydraulic system components	-	°
System sealing efficiency check	-	°
Exchanger washing	-	°
Electrical and electronic component efficiency check	-	°

N.B.: the above maintenance operations must be performed in compliance with current standards.

K - Cleaning

Clean the external boiler panels only, using a damp, soapy cloth.

For stubborn stains, dampen the cloth with a 50% water and denatured alcohol mixture, or use specific products.

! Never use fuel and/or sponges soaked in abrasive solutions or powder detergents.

! Do not clean the boiler without having disconnected it from the mains power supply, by setting the power switch to "off".

I - Fault resets

To restore operation (unblock alarms).

Faults A01-02-03

Set the function selector to OFF **🔌**, wait 5-6 seconds then turn the selector back to the required setting.

If the unblock attempts do not reactivate the boiler, please request support from the Technical Assistance Service.

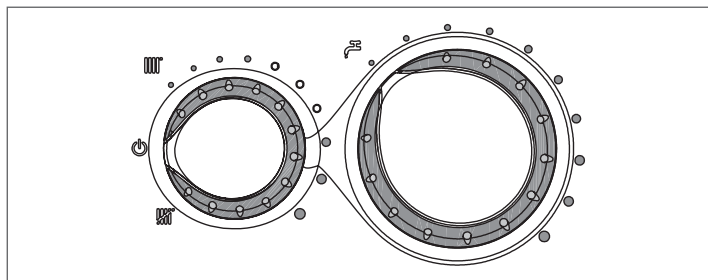

Fault A04

The digital display shows the fault code together with the symbol **👤**.

Check the pressure shown on the water gauge:

if the pressure is less than 0.3 bar, set the function selector to **🔌** (OFF) and adjust the filling tap until the pressure is between 1 and 1.5 bar.

TECHNICAL DATA

DESCRIPTION	FASTECH 24 KI			FASTECH 24 KIS			
	G20	G30	G31	G20	G30	G31	
Gas	G20			G30			
Appliance category • Country of destination	II2H3+ • (JO-SRB-MK-LB-EG) II2H3B/P • (AL)			II2H3+ • (JO-SRB-MK-LB-EG) II2H3B/P • (AL)			
Device type	B11BS			B22P-B52P; C12-C12x; C22; C32-C32x; C42-C42x; C52- C52x; C82-C82x; C92-C92x			
Heating							
Nominal heat input	kW	26,70			25,80		
Nominal heat output	kW	24,56			23,94		
Reduced heat input	kW	11,50			8,90		
Reduced heat output	kW	10,19			7,52		
Domestic hot water							
Nominal heat input	kW	26,70			25,80		
Nominal heat output	kW	24,56			23,94		
Reduced heat input	kW	9,00			8,90		
Reduced heat output	kW	7,97			7,52		
Useful efficiency Pn max - Pn min	%	92,0 - 88,6			92,8 - 84,5		
Useful efficiency 30% (47° return)	%	90,8			91,8		
Combustion efficiency	%	92,6			93,0		
Flue gas mass flow rate maximum power	g/s	16,080	15,370	15,800	14,360	14,330	14,620
Flue gas mass flow rate minimum power	g/s	15,270	14,060	14,350	15,600	15,730	16,210
Air flow rate	Nm ³ /h	44,547	41,400	42,618	39,743	38,545	39,385
Flue flow rate	Nm ³ /h	47,224	43,356	44,681	42,330	40,436	41,378
Excess air index (λ) maximum power		1,740	1,709	1,736	1,607	1,647	1,661
Excess air index (λ) minimum power		3,859	3,704	3,733	5,100	5,385	5,480
Flue temperature (min/max power)	°C	119/90	118/91	116/91	141/108	145/109	143/109
CO ₂ at maximum**/minimum**	%	6,80/3,00	8,20/3,80	7,90/3,70	7,30/2,30	8,50/2,60	8,25/2,50
CO S.A. at maximum**/minimum** less than	p.p.m.	150/40	160/50	90/40	120/160	200/210	160/200
NOx S.A. at maximum**/minimum** less than	ppm	180/190	250/150	220/140	160/100	230/180	250/110
NOx Class		3			3		
Maximum heating operating pressure	bar	3			3		
Minimum pressure for standard operation	bar	0,25-0,45			0,25-0,45		
Maximum temperature allowed	°C	90			90		
Boiler water temperature selection range (±3°C)	°C	40/80			40/80		
Electrical power supply	Volt-Hz	230-50			230-50		
Pump head available to the system	mbar	118			176		
at a flow rate of	l/h	1.000			1.000		
Maximum electric power consumption	W	61			97		
Pump electrical output (1.000 l/h)	W	54			54		
Electrical protection rating	IP	X5D			X5D		
Expansion vessel	l	8			8		
Expansion vessel pre-load	bar	1			1		
Maximum DHW operating pressure	bar	6			6		
Minimum DHW operating pressure	bar	0,15			0,15		
Quantity of hot water with Δt 25°C	l/min	14,1			13,7		
Quantity of hot water with Δt 30°C	l/min	11,7			11,4		
Quantity of hot water with Δt 35°C	l/min	10,1			9,8		
Domestic hot water temperature selection range (±3°C)	°C	37-60			37-60		
Minimum DHW flow rate	l/min	2			2		
Flow rate limiter	l/min	10			10		

** **KI model:** Pipe diameter 130 mm - length 0.5 m. - check performed in heating mode with water temperature 80°C-60°C

KIS model: Checked carried out with concentric pipe ø 60-100 - length 0,85m - water temperature 80°C-60°C - flue gas flange of suitable diameter installed

MULTIGAS TABLE

DESCRIPTION		Methane gas (G20)	Butane (G30)	Propane (G31)
Lower Wobbe index (at 15°C-1013 mbar)	MJ/m ³ S	45,67	80,58	70,69
Net Calorific Value	MJ/m ³ S	34,02	116,09	88
Supply nominal pressure (I12H3+)	mbar (mm H ₂ O)	20 (203,9)	28 - 30 (285,5 - 305,9)	37 (377,3)
Supply nominal pressure (I12H3B/P)	mbar (mm H ₂ O)	20 (203,9)	30 (305,9)	30 (305,9)
Supply minimum pressure	mbar (mm H ₂ O)	13,5 (137,7)		
FASTECH 24 KI				
Burner: number of nozzles	n°	12	12	12
diameter of nozzles	ø mm	1,35	0,77	0,77
CH maximum gas capacity	Sm ³ /h	2,82		
	kg/h		2,10	2,07
DHW maximum gas capacity	Sm ³ /h	2,82		
	kg/h		2,10	2,07
CH minimum gas capacity	Sm ³ /h	1,22		
	kg/h		0,91	0,89
DHW minimum gas capacity	Sm ³ /h	0,95		
	kg/h		0,71	0,70
CH maximum pressure	(mbar)	10,10	28,00	35,50
	(mm H ₂ O)	102,99	285,52	362,00
DHW maximum pressure	(mbar)	10,10	28,00	35,50
	(mm H ₂ O)	102,99	285,52	362,00
CH minimum pressure	(mbar)	1,90	5,60	7,30
	(mm H ₂ O)	19,37	57,10	74,44
DHW minimum pressure	(mbar)	1,20	3,50	4,60
	(mm H ₂ O)	12,24	35,69	46,91
FASTECH 24 KIS				
Burner: number of nozzles	n°	11	11	11
diameter of nozzles	ø mm	1,35	0,78	0,78
CH maximum gas capacity	Sm ³ /h	2,73		
	kg/h		2,03	2,00
DHW maximum gas capacity	Sm ³ /h	2,73		
	kg/h		2,03	2,00
CH minimum gas capacity	Sm ³ /h	0,94		
	kg/h		0,70	0,69
DHW minimum gas capacity	Sm ³ /h	0,94		
	kg/h		0,70	0,69
CH maximum pressure	(mbar)	11,80	27,80	35,80
	(mm H ₂ O)	120,33	283,48	365,06
DHW maximum pressure	(mbar)	11,80	27,80	35,80
	(mm H ₂ O)	120,33	283,48	365,06
CH minimum pressure	(mbar)	1,50	3,30	4,30
	(mm H ₂ O)	15,30	33,65	43,85
DHW minimum pressure	(mbar)	1,50	3,30	4,30
	(mm H ₂ O)	15,30	33,65	43,85

All pressures are measured with compensation tube disconnected (if present).